



JEE (MAIN) 2026

QUESTION PAPER & ANSWER KEY

(21-01-2026) Evening

Time : 3 Hrs

M.M.: 300

General Instruction

1. The test is of 3 hours duration and the maximum marks is 300.
2. The question paper consists of 3 Parts (Part I: Mathematics, Part II: Physics, Part III: Chemistry). Each Part has two sections (Section 1 & Section 2).
3. Section A contains 20 Multiple Choice Questions. Each question has 4 choices (1), (2), (3) and (4), out of which ONLY ONE CHOICE is correct.
4. Section B will contain only 5 (five) questions per subject, and candidates will be required to attempt all 5 (five) questions. The answer to each question is an integer ranging from 0 to 999 (both inclusive).
5. No candidate is allowed to carry any textual material, printed or written, bits of papers, pager, mobile phone, any electronic device, etc. inside the examination room/hall.
6. Rough work is to be done on the space provided for this purpose in the Test Booklet only.
7. On completion of the test, the candidate must hand over the Answer Sheet to the Invigilator on duty in the Room/Hall. However, the candidates are allowed to take away this Test Booklet with them.
8. Do not fold or make any stray mark on the Answer Sheet (OMR).

Marking Scheme

1. Section – A: + 4 for correct answer, –1 (negative marking) for incorrect answer, 0 for all other cases.
2. Section – B: + 4 for correct answer, –1 (negative marking) for incorrect answer, 0 for all other cases.

MATHEMATICS

SECTION - A

Multiple Choice Questions: This section contains 20 multiple choice questions. Each question has 4 choices (1), (2), (3) and (4), out of which **ONLY ONE** is correct.

Choose the correct answer:

1. If the line $\alpha x + 4y = \sqrt{7}$, where $\alpha \in \mathbb{R}$, touches the ellipse $3x^2 + 4y^2 = 1$ at the point P in the first quadrant, then one of the focal distances of P is:

(1) $\frac{1}{\sqrt{3}} - \frac{1}{2\sqrt{5}}$	(2) $\frac{1}{\sqrt{3}} + \frac{1}{2\sqrt{5}}$
(3) $\frac{1}{\sqrt{3}} + \frac{1}{2\sqrt{7}}$	(4) $\frac{1}{\sqrt{3}} - \frac{1}{2\sqrt{11}}$
2. Let $A = \{x : |x^2 - 10| \leq 6\}$ and $B = \{x : |x - 2| > 1\}$. Then

(1) $A - B = [2, 3]$	(2) $A \cup B = (-\infty, 1] \cup (2, \infty)$
(3) $B - A = (-\infty, -4) \cup (-2, 1) \cup (4, \infty)$	(4) $A \cap B = [-4, -2] \cup [3, 4]$
3. Let one end of a focal chord of the parabola $y^2 = 16x$ be $(16, 16)$. If $P(\alpha, \beta)$ divides this focal chord internally in the ratio 5 : 2, then the minimum value of $\alpha + \beta$ is equal to:

(1) 5	(2) 7
(3) 16	(4) 22
4. The largest $n \in \mathbb{N}$, for which 7^n divides $101!$, is:

(1) 16	(2) 15
(3) 18	(4) 19
5. Let $A = \{2, 3, 5, 7, 9\}$. Let R be the relation on A defined by xRy if and only if $2x \leq 3y$. Let l be the number of elements in R , and m be the minimum number of elements required to be

added in R to make it a symmetric relation.

Then $l + m$ is equal to:

- | | |
|--------|--------|
| (1) 23 | (2) 27 |
| (3) 25 | (4) 21 |
6. A random variable X takes values 0, 1, 2, 3 with probabilities $\frac{2a+1}{30}, \frac{8a-1}{30}, \frac{4a+1}{30}, b$ respectively, where $a, b \in \mathbb{R}$. Let μ and σ respectively be the mean and standard deviation of X such that $\sigma^2 + \mu^2 = 2$. Then $\frac{a}{b}$ is equal to :

(1) 60	(2) 3
(3) 30	(4) 12
 7. Let z be the complex number satisfying $|z - 5| \leq 3$ and having maximum positive principal argument. Then $34 \left| \frac{5z - 12}{5iz + 16} \right|^2$ is equal to :

(1) 20	(2) 12
(3) 16	(4) 26
 8. Let the line L_1 be parallel to the vector $-3\hat{i} + 2\hat{j} + 4\hat{k}$ and pass through the point $(2, 6, 7)$, and the line L_2 be parallel to the vector $2\hat{i} + \hat{j} + 3\hat{k}$ and pass through the point $(4, 3, 5)$. If the line L_3 is parallel to the vector $-3\hat{i} + 5\hat{j} + 16\hat{k}$ and intersects the lines L_1 and L_2 at the points C and D , respectively, then $|\overline{CD}|^2$ is equal to :

(1) 171	(2) 290
(3) 312	(4) 89



9. If the system of equations
 $3x + y + 4z = 3$
 $2x + \alpha y - z = -3$
 $x + 2y + z = 4$
 has no solution, then the value of α is equal to :
- (1) 23
 (2) 13
 (3) 4
 (4) 19
10. For the matrices $A = \begin{bmatrix} 3 & -4 \\ 1 & -1 \end{bmatrix}$ and $B = \begin{bmatrix} -29 & 49 \\ -13 & 18 \end{bmatrix}$, if $(A^{15} + B) \begin{bmatrix} x \\ y \end{bmatrix} = \begin{bmatrix} 0 \\ 0 \end{bmatrix}$, then among the following which one is true?
- (1) $x = 18, y = 11$ (2) $x = 11, y = 2$
 (3) $x = 16, y = 3$ (4) $x = 5, y = 7$
11. Let $f(x) = x^3 + x^2 f'(1) + 2x f''(2) + f'''(3)$, $x \in \mathbf{R}$. Then the value of $f'(5)$ is
- (1) $\frac{62}{5}$ (2) $\frac{657}{5}$
 (3) $\frac{2}{5}$ (4) $\frac{117}{5}$
12. Let $f: \mathbf{R} \rightarrow \mathbf{R}$ be a twice differentiable function such that $f''(x) > 0$ for all $x \in \mathbf{R}$ and $f'(a-1) = 0$ where a is a real number. Let $g(x) = f(\tan^2 x - 2\tan x + a)$, $0 < x < \frac{\pi}{2}$. Consider the following statements:
- (I) g is increasing in $\left(0, \frac{\pi}{4}\right)$
 (II) g is decreasing in $\left(\frac{\pi}{2}, \frac{\pi}{4}\right)$
- Then,
- (1) Only (I) is true
 (2) Both (I) and (II) are true
 (3) Only (II) is true
 (4) Neither (I) nor (II) is true
13. Let $y = y(x)$ be the solution of the differential equation
 $\sec x \frac{dy}{dx} - 2y = 2 + 3 \sin x$, $x \in \left(-\frac{\pi}{2}, \frac{\pi}{2}\right)$,
 $y(0) = -\frac{7}{4}$. Then $y\left(\frac{\pi}{6}\right)$ is equal to
- (1) $-\frac{5}{4}$ (2) $-\frac{5}{2}$
 (3) $-3\sqrt{2} - 7$ (4) $-3\sqrt{3} - 7$
14. Let $a_1, \frac{a_2}{2}, \frac{a_3}{2^2}, \dots, \frac{a_{10}}{2^9}$ be a G.P. of common ratio $\frac{1}{\sqrt{2}}$. If $a_1 + a_2 + \dots + a_{10} = 62$, then a_1 is equal to
- (1) $\sqrt{2} - 1$ (2) $2(2 - \sqrt{2})$
 (3) $2(\sqrt{2} - 1)$ (4) $2 - \sqrt{2}$
15. The positive integer n , for which the solutions of the equation $x(x+2) + (x+2)(x+4) + \dots + (x+2n-2)(x+2n) = \frac{8n}{3}$ are two consecutive even integers, is:
- (1) 3 (2) 12
 (3) 6 (4) 9
16. Let $y^2 = 12x$ be the parabola with its vertex at O . Let P be a point on the parabola and A be a point on the x -axis such that $\angle OPA = 90^\circ$. Then the locus of the centroid of such triangles OPA is :
- (1) $y^2 - 9x + 6 = 0$ (2) $y^2 - 4x + 8 = 0$
 (3) $y^2 - 6x + 4 = 0$ (4) $y^2 - 2x + 8 = 0$
17. For a triangle ABC , let $\vec{p} = \vec{BC}$, $\vec{q} = \vec{CA}$ and $\vec{r} = \vec{BA}$. If $|\vec{p}| = 2\sqrt{3}$, $|\vec{q}| = 2$ and $\cos\theta = \frac{1}{\sqrt{3}}$, where θ is the angle between \vec{p} and \vec{q} , then $|\vec{p} \times (\vec{q} - 3\vec{r})|^2 + 3|\vec{r}|^2$ is equal to :
- (1) 200 (2) 220
 (3) 410 (4) 340

18. Let α and β be the roots of the equation $x^2 + 2ax + (3a + 10) = 0$ such that $\alpha < 1 < \beta$.

Then the set of all possible values of a is:

(1) $\left(-\infty, \frac{-11}{5}\right)$ (2) $(-\infty, -3)$

(3) $\left(-\infty, \frac{-11}{5}\right) \cup (5, \infty)$ (4)

$(-\infty, -2) \cup (5, \infty)$

19 If the area of the region $\{(x, y) : 1 - 2x \leq y \leq 4 - x^2, x \geq 0, y \geq 0\}$ is

$\frac{\alpha}{\beta}, \alpha, \beta \in \mathbf{N}, \gcd(\alpha, \beta) = 1$, then the value of

$(\alpha + \beta)$ is :

(1) 67 (2) 73

(3) 85 (4) 91

20 Let the line L pass through the point $(-3, 5, 2)$ and make equal angles with the positive coordinate axes. If the distance of L from the

point $(-2, r, 1)$ is $\sqrt{\frac{14}{3}}$, then the sum of all

possible values of r is :

(1) 16 (2) 10

(3) 12 (4) 6

SECTION - B

Numerical Value Type Questions: This section contains 5 Numerical based questions. The answer

to each question should be rounded-off to the nearest integer.

21. If P is a point on the circle $x^2 + y^2 = 4$, Q is a point on the straight line $5x + y + 2 = 0$ and $x - y + 1 = 0$ is the perpendicular bisector of PQ , then 13 times the sum of abscissa of all such points P is

22. If

$$\int_0^1 4 \cot^{-1}(1 - 2x + 4x^2) dx = a \tan^{-1}(2) - b \log_e(5)$$

, where $a, b \in \mathbf{N}$, then $(2a + b)$ is equal to

23. If

$$\left(\frac{1}{{}^{15}C_0} + \frac{1}{{}^{15}C_1}\right) \left(\frac{1}{{}^{15}C_1} + \frac{1}{{}^{15}C_2}\right) \dots \left(\frac{1}{{}^{15}C_{12}} + \frac{1}{{}^{15}C_{13}}\right)$$

$$= \frac{\alpha^{13}}{{}^{14}C_0 {}^{14}C_1 \dots {}^{14}C_{12}}$$

then 30α is equal to _____

24. Let the maximum value of $(\sin^{-1}x)^2 + (\cos^{-1}x)^2$

for $x \in \left[-\frac{\sqrt{3}}{2}, \frac{1}{\sqrt{2}}\right]$ be $\frac{m}{n} \pi^2$, where $\gcd(m, n) = 1$. Then $m + n$ is equal to _____.

25. Let $[.]$ denote the greatest integer function and

$$f(x) = \lim_{n \rightarrow \infty} \frac{1}{n^3} \sum_{k=1}^n \left[\frac{k^2}{3^x} \right].$$

Then $12 \sum_{j=1}^{\infty} f(j)$ is equal to _____.

Physics

SECTION - A

Multiple Choice Questions: This section contains 20 multiple choice questions. Each question has 4 choices (1), (2), (3) and (4), out of which **ONLY ONE** is correct.

Choose the correct answer:

26. An infinitely long straight wire carrying current I is bent in a planner shape as shown in the diagram. The radius of the circular part is r . The magnetic field at the centre O of the circular loop is :

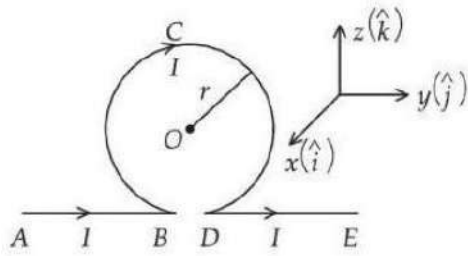

- (1) $-\frac{\mu_0 I}{2\pi r}(\pi+1)\hat{i}$ (2) $-\frac{\mu_0 I}{2\pi r}(\pi-1)\hat{i}$
 (3) $\frac{\mu_0 I}{2\pi r}(\pi+1)\hat{i}$ (4) $\frac{\mu_0 I}{2\pi r}(\pi-1)\hat{i}$

27. The pulley shown in figure is made using a thin rim and two rods of length equal to diameter of the rim. The rim and each rod have a mass of M . Two blocks of mass of M and m are attached to two ends of a light string passing over the pulley, which is hinged to rotate freely in vertical plane about its center. The magnitudes of the acceleration experienced by the blocks is _____ (assume no slipping of string on pulley).

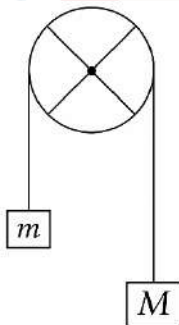

- (1) $\frac{(M-m)g}{2M+m}$ (2) $\frac{(M-m)g}{\left[\frac{13}{6}M+m\right]}$
 (3) $\frac{(M-m)g}{M+m}$ (4) $\frac{(M-m)g}{\left[\frac{8}{3}M+m\right]}$

28. The energy of an electron in an orbit of the Bohr's atom is $-0.04E_0$ eV where E_0 is the ground state energy. If L is the angular momentum of the electron in this orbit and h is the Planck's constant, then $\frac{2\pi L}{h}$ is _____.
 (1) 2 (2) 5
 (3) 4 (4) 6

29. Consider two identical metallic spheres of radius R each having charge Q and mass m . Their centers have an initial separation of $4R$. Both the spheres are given an initial speed of u towards each other. The minimum value of u , so that they can just touch each other is :
 (Take $k = \frac{1}{4\pi\epsilon_0}$ and assume $kQ^2 > Gm^2$ where G is the Gravitational constant)

- (1) $\sqrt{\frac{kQ^2}{2mR}\left(1-\frac{Gm^2}{2kQ^2}\right)}$
 (2) $\sqrt{\frac{kQ^2}{2mR}\left(1-\frac{Gm^2}{kQ^2}\right)}$
 (3) $\sqrt{\frac{kQ^2}{4mR}\left(1-\frac{Gm^2}{kQ^2}\right)}$
 (4) $\sqrt{\frac{kQ^2}{4mR}\left(1+\frac{Gm^2}{kQ^2}\right)}$

30. A large drum having radius R is spinning around its axis with angular velocity ω , as shown in figure. The minimum value of ω so that a body of mass M remains stuck to the inner wall of the drum, taking the coefficient of friction between the drum surface and mass M as μ , is :

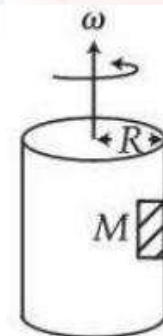

- (1) $\sqrt{\frac{2g}{\mu R}}$ (2) $\sqrt{\frac{\mu g}{R}}$
 (3) $\sqrt{\frac{g}{\mu R}}$ (4) $\sqrt{\frac{g}{2\mu R}}$

31. The kinetic energy of a simple harmonic oscillator is oscillating with angular frequency of 176rad/s . The frequency of this simple harmonic oscillator is _____ Hz. [take

$$\pi = \frac{22}{7}]$$

- (1) 28 (2) 88
(3) 176 (4) 14

32. A river of width 200 m is flowing from west to east with a speed of 18 km/h . A boat, moving with speed of 36 km/h in still water, is made to travel one-round trip (bank to bank of the river). Minimum time taken by the boat for this journey and also the displacement along the river bank are _____ and _____ respectively.

- (1) 40 s and 200 m (2) 20 s and 100 m
(3) 40 s and 100 m (4) 40 s and 0 m

33. A capacitor C is first charged fully with potential difference of V_0 and disconnected from the battery. The charged capacitor is connected across an inductor having inductance L . In t s 25% of the initial energy in the capacitor is transferred to the inductor. The value of t is _____ s.

- (1) $\frac{\pi\sqrt{LC}}{3}$ (2) $\frac{\pi\sqrt{LC}}{6}$
(3) $\frac{\pi\sqrt{LC}}{2}$ (4) $\pi\sqrt{\frac{LC}{2}}$

34. The charge stored by the capacitor C in the given circuit in the steady state is _____ μC

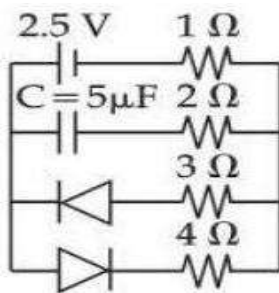

- (1) 5 (2) 12.5
(3) 10 (4) 7.5

35. Keeping the significant figures in view, the sum of the physical quantities 52.01 m , 153.2 m and 0.123 m is

- (1) 205 m (2) 205.3 m
(3) 205.333 m (4) 205.33 m

36. A battery with EMF E and internal resistance r is connected across a resistance R . The power consumption in R will be maximum when

- (1) $R = r$ (2) $R = 2r$
(3) $R = r/2$ (4) $R = \sqrt{2}r$

37. Surface tension of two liquids (having same densities), T_1 and T_2 , are measured using capillary rise method utilizing two tubes with inner radii of r_1 and r_2 where $r_1 > r_2$. The measured liquid heights in these tubes are h_1 and h_2 respectively. [Ignore the weight of the liquid about the lowest point of meniscus]. The heights h_1 and h_2 and surfaces tensions T_1 and T_2 satisfy the relation:

- (1) $h_1 = h_2$ and $T_1 = T_2$
(2) $h_1 > h_2$ and $T_1 < T_2$
(3) $h_1 > h_2$ and $T_1 = T_2$
(4) $h_1 < h_2$ and $T_1 = T_2$

38. The r.m.s. speed of oxygen molecules at 47°C is equal to that of the hydrogen molecules kept at _____ $^\circ\text{C}$. (Mass of oxygen molecule/mass of hydrogen molecule = $32/2$)

- (1) -253 (2) -100
(3) -235 (4) -20

39. Two cars A and B each of mass 10^3 kg are moving on parallel tracks separated by a distance of 10 m , in same direction with speeds 72 km/h and 36 km/h . The magnitude of angular momentum of car A with respect to car B is _____ J.s.

- (1) 3×10^5 (2) 3.6×10^5
(3) 10^5 (4) 2×10^5

40. Two known resistances of $R \Omega$ and $2R \Omega$ and one unknown resistance $X\Omega$ are connected in a circuit as shown in the figure. If the equivalent resistance between points A and B in the circuit is $X\Omega$, then the value of X is _____ Ω .

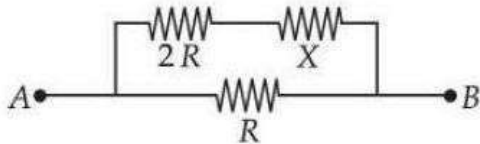

- (1) $(\sqrt{3}-1)R$
 (2) $2(\sqrt{3}-1)R$
 (3) $(\sqrt{3}+1)R$
 (4) R
41. Given below are two statements:

Statement-I: In a Young's double slit experiment, the angular separation of fringes will increase as the screen is moved away from the plane of the slits.

Statement-II: In a Young's double slit experiment, the angular separation of fringes will increase when monochromatic source is replaced by another monochromatic source of higher wavelength.

In the light of the above statements, choose the correct answer from the options given below :

- (1) Statement-I is false but statement-II is true
 (2) Both Statement-I and statement-II are false
 (3) Both Statement-I and statement-II are true
 (4) Statement-I is true but statement-II is false
42. The total length of potentiometer wire AB is 50 cm in the arrangement as shown in figure. If P is the point where the galvanometer shows zero reading then the length AP is _____ cm.

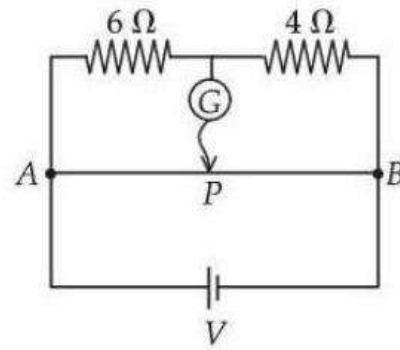

- (1) 30
 (2) 25
 (3) 20
 (4) 15

43. A body of mass 2 kg is moving along x -direction such that its displacement as function of time is given by $x(t) = \alpha t^2 + \beta t + \gamma$ m, where $\alpha = 1 \text{ m/s}^2$, $\beta = 1 \text{ m/s}$ and $\gamma = 1 \text{ m}$. The work done on the body during the time interval $t = 2 \text{ s}$ to $t = 3 \text{ s}$, is _____ J.

- (1) 49
 (2) 42
 (3) 12
 (4) 24

44. As shown in the diagram, when the incident ray is parallel to base of the prism, the emergent ray grazes along the second surface.

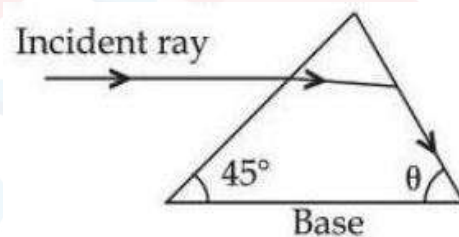

If refractive index of the material of prism is $\sqrt{2}$, the angle θ of prism is.

- (1) 75°
 (2) 60°
 (3) 45°
 (4) 90°

45. A spherical body of radius r and density σ falls freely through a viscous liquid having density ρ and viscosity η and attains a terminal velocity v_0 . Estimated maximum error in the quantity η is :

(Ignore errors associated with σ , ρ and g , gravitational acceleration)

(1) $\frac{2\Delta r}{r} + \frac{\Delta v_0}{v_0}$ (2) $2\frac{\Delta r}{r} - \frac{\Delta v_0}{v_0}$
 (3) $2\left[\frac{\Delta r}{r} - \frac{\Delta v_0}{v_0}\right]$ (4) $2\left[\frac{\Delta r}{r} + \frac{\Delta v_0}{v_0}\right]$

SECTION - B

Numerical Value Type Questions: This section contains 5 Numerical based questions. The answer to each question should be rounded-off to the nearest integer.

46. The terminal velocity of a metallic ball of radius 6 mm in a viscous fluid is 20 cm/s. The terminal velocity of another ball of same material and having radius 3 mm in the same fluid will be _____ cm/s.
47. A diatomic gas ($\gamma = 1.4$) does 100 J of work when it is expanded isobarically. Then the heat given to the gas _____ J.

48. In a Young's double slit experiment set up, the two slits are kept 0.4 mm apart and screen is placed at 1 m from slits. If a thin transparent sheet of thickness 20 μm is introduced in front of one of the slits then center bright fringe shifts by 20 mm on the screen. The refractive index of transparent sheet is given by $\frac{\alpha}{10}$, where α is _____.

49. A particle having electric charge 3×10^{-19} C and mass 6×10^{-27} kg is accelerated by applying an electric potential of 1.21 V. Wavelength of the matter wave associated with the particle is $\alpha \times 10^{-12}$ m. The value of α is _____.

(Take Planck's constant = 6.6×10^{-34} J.s)

50. An electromagnetic wave of frequency 100 MHz propagates through a medium of conductivity, $\sigma = 10$ mho/m. The ratio of maximum conduction current density to maximum displacement current density is _____.

[Take $\frac{1}{4\pi\epsilon_0} = 9 \times 10^9 \text{ Nm}^2 / \text{C}^2$]

Chemistry

SECTION - A

Multiple Choice Questions: This section contains 20 multiple choice questions. Each question has 4 choices (1), (2), (3) and (4), out of which **ONLY ONE** is correct.

Choose the correct answer:

51. Given below are some of the statements about Mn and Mn_2O_7 . Identify the correct statements.
- A. Mn forms the oxide Mn_2O_7 , in which Mn is in its highest oxidation state.

- B. Oxygen stabilizes the Mn in higher oxidation states by forming multiple bonds with Mn.
- C. Mn_2O_7 is an ionic oxide.
- D. The structure of Mn_2O_7 consists of one bridged oxygen.

Choose the **correct** answer from the options given below :

- (1) A, B and D only (2) A, B and C only
 (3) A, C and D only (4) A, B, C and D

52. Given below are two statements :

Statement I: Crystal Field Stabilization Energy (CFSE) of $[\text{Cr}(\text{H}_2\text{O})_6]^{2+}$ is greater than that of $[\text{Mn}(\text{H}_2\text{O})_6]^{2+}$.

Statement II: Potassium ferricyanide has a greater spin-only magnetic moment than sodium ferrocyanide. In the light of the above statements, choose the **correct** answer from the options given below :

- (1) Statement I is false but Statement II is true
- (2) Both Statement I and Statement II are true
- (3) Statement I is true but Statement II is false
- (4) Both Statement I and Statement II are false

53. Given below are two statements :

Statement I: Compound (X), shown below, dissolves in NaHCO_3 solution and has two chiral carbon atoms

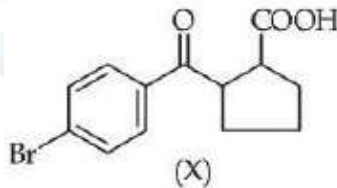

Statement II: Compound (Y), shown below, has two carbons with sp^3 hybridization, one carbon with sp^2 and one carbon with sp hybridization (Y). In the light of

the above statements, choose the **correct** answer from the options given below :

- (1) Both Statement I and Statement II are false
- (2) Statement I is false but Statement II is true
- (3) Statement I is true but Statement II is false
- (4) Both Statement I and Statement II are true

54. Aqueous HCl reacts with $\text{MnO}_2(\text{s})$ to form $\text{MnCl}_2(\text{aq})$, $\text{Cl}_2(\text{g})$ and $\text{H}_2\text{O}(\text{l})$. What is the weight (in g) of Cl_2 liberated when 8.7 g of

$\text{MnO}_2(\text{s})$ is reacted with excess aqueous HCl solution?

(Given Molar mass in g mol^{-1} Mn = 55, Cl = 35.5, O = 16, H = 1)

- (1) 7.1
- (2) 14.2
- (3) 21.3
- (4) 71

55. Consider the following data:

$$\Delta_f H^\ominus (\text{methane, g}) = -X \text{ kJmol}^{-1}$$

$$\text{Enthalpy of sublimation of graphite} = Y \text{ kJmol}^{-1}$$

$$\text{Dissociation enthalpy of } \text{H}_2 = Z \text{ kJmol}^{-1}$$

The bond enthalpy of C-H bond is given by :

- (1) $\frac{-X + Y + Z}{4}$
- (2) $\frac{X + Y + 4Z}{2}$
- (3) $\frac{X + Y + 2Z}{4}$
- (4) $X + Y + Z$

56. For a closed circuit Daniell cell, which of the following plots is the accurate one at a given temperature?

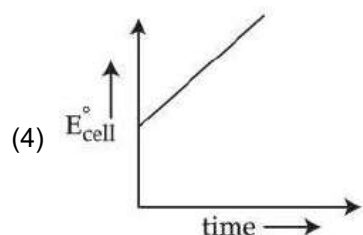
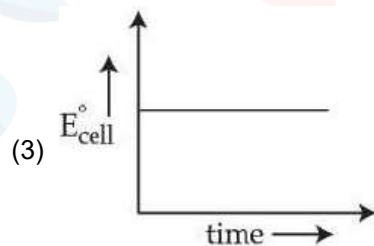
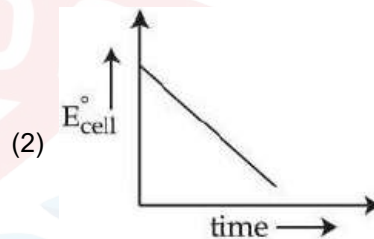
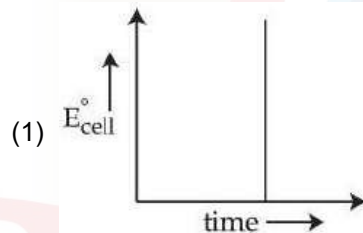

57. Given below are four compounds :

- n-propyl chloride
- iso-propyl chloride
- sec-butyl chloride
- neo-pentyl chloride

Percentage of carbon in the one which exhibits optical isomerism is :

- 46
- 52
- 56
- 40

58. Given below are two statements :

Statement I : The correct order in terms of bond dissociation enthalpy is $\text{Cl}_2 > \text{Br}_2 > \text{F}_2 > \text{I}_2$.

Statement II : The correct trend in the covalent character of the metal halides is $[\text{SnCl}_4 > \text{SnCl}_2]$, $[\text{PbCl}_4 > \text{PbCl}_2]$ and $[\text{UF}_4 > \text{UF}_6]$.

In the light of the above statements, choose the **correct** answer from the options given below :

- Statement I is true but Statement II is false
- Both Statement I and Statement II are false
- Statement I is false but Statement II is true
- Both Statement I and Statement II are true

59. The correct order of reactivity of the following benzyl halides towards reaction with KCN is :



- $b > a > d > c$
- $a > b > d > c$
- $b > a > c > d$
- $a > b > c > d$

60. On heating a mixture of common salt and $\text{K}_2\text{Cr}_2\text{O}_7$ in equal amount along with concentrated H_2SO_4 in a test tube, a gas is evolved. Formula of the gas evolved and

oxidation state of the central metal atom in the gas respectively are:

- $\text{Cr}_2\text{O}_2\text{Cl}_2$ and +6
- CrO_2Cl_2 and +6
- $\text{Cr}_2\text{O}_2\text{Cl}_2$ and +3
- CrO_2Cl_2 and +5

61. Match List-I with List-II.

	List-I Pair of Compounds		List-II Type of Isomers
A.	2-Methylpropene and but-1-ene	I.	Stereoisomers
B.	Cis-but-2-ene and trans-but-2-ene	II.	Position isomers
C.	2-Butanol and diethyl ether	III.	Chain isomers
D.	But-1-ene and but-2-ene	IV.	Functional group isomers

Choose the **correct** answer from the options given below :

- A-III, B-I, C-II, D-IV
- A-III, B-I, C-IV, D-II
- A-I, B-IV, C-III, D-II
- A-II, B-I, C-IV, D-III

62. The correct increasing order of C–H(A), C–O(B), C = O(C) and C ≡ N(D) bonds in terms of covalent bond length is :

- $D < C < B < A$
- $A < D < C < B$
- $A < B < C < D$
- $D < C < A < B$

63. Consider the following spectral lines for atomic hydrogen:

- First line of Paschen series
- Second line of Balmer series
- Third line of Paschen series
- Fourth line of Bracket series

The correct arrangement of the above lines in ascending order of energy is

- $D < A < C < B$
- $A < B < C < D$
- $C < D < B < A$
- $D < C < A < B$

64. Given below are two statements:

Statement I: The correct order in terms of atomic/ionic radii is $Al > Mg > Mg^{2+} > Al^{3+}$.

Statement II: The correct order in terms of the magnitude of electron gain enthalpy is $Cl > Br > S > O$.

In the light of the above statements, choose the **correct** answer from the options given below.

- (1) Statement I is true but statement II is false
- (2) Statement I is false but statement II is true
- (3) Both statement I and statement II are false
- (4) Both statement I and statement II are true

65. By usual analysis, 1.00 g of compound (X) gave 1.79 g of magnesium pyrophosphate. The percentage of phosphorus in compound (X) is (nearest integer)

(Given, molar mass in $g\ mol^{-1}$: O = 16, Mg = 24,

P = 31)

- (1) 50
- (2) 40
- (3) 30
- (4) 20

66. Match **List-I** with **List-II**

	List-I Reagents		List-II Reaction Name (Involving aldehydes)
A.	$H_2, Pd-BaSO_4$	I.	Etard Reaction
B.	$SnCl_2, HCl$	II.	Rosenmund Reduction
C.	CrO_2Cl_2, CS_2	III.	Gatterman- Koch Reaction
D.	$CO, HCl,$ Anhyd. $AlCl_3$	IV.	Stephen Reaction

Choose the **correct** answer from the options given below.

(1) A - IV, B - III, C - I, D - II

(2) A - II, B - IV, C - I, D - III

(3) A - IV, B - I, C - II, D - III

(4) A - II, B - III, C - IV, D - I

67. The correct order of the rate of the reaction for the following reaction with respect to nucleophiles is

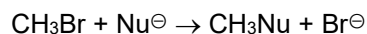

(1) $CH_3COO^- > PhO^- > ^-OH > ClO_4^-$

(2) $^-OH > PhO^- > CH_3COO^- > ClO_4^-$

(3) $ClO_4^- > CH_3COO^- > ^-OH > PhO^-$

(4) $PhO^- > ^-OH > CH_3COO^- > ClO_4^-$

68. Decomposition of A is a first order reaction at T(K) and is given by $A(g) \rightarrow B(g) + C(g)$.

In a closed 1 L vessel, 1 bar A(g) is allowed to decompose at T(K). After 100 minutes, the total pressure was 1.5 bar. What is the rate constant (in min^{-1}) of the reaction? ($\log 2 = 0.3$)

- (1) 6.9×10^{-3}
- (2) 6.9×10^{-4}
- (3) 6.9×10^{-1}
- (4) 6.9×10^{-2}

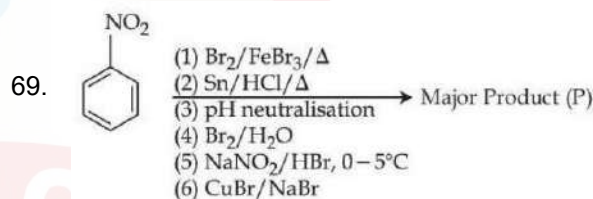

Consider the above sequence of reactions. The number of bromine atom(s) in the final product (P) will be :

- (1) 3
- (2) 1
- (3) 6
- (4) 5

70. The **correct** statements are :

- A. Activation energy for enzyme catalysed hydrolysis of sucrose is lower than that of acid catalysed hydrolysis.
- B. During denaturation, secondary and tertiary structures of a protein are destroyed but primary structure remains intact.
- C. Nucleotides are joined together by glycosidic linkage between C_1 and C_4 carbons of the pentose sugar.

D. Quaternary structure of proteins represents overall folding of the polypeptide chain.

Choose the **correct** answer from the options given below:

- (1) A, C and D Only (2) B and C Only
(3) A and B Only (4) A, B and D Only

SECTION - B

Numerical Value Type Questions: This section contains 5 Numerical based questions. The answer to each question should be rounded-off to the nearest integer.

71. The first and second ionization constants of H_2X are 2.5×10^{-8} and 1.0×10^{-13} respectively. The concentration of X^{2-} in 0.1 M H_2X solution is _____ $\times 10^{-15}$ M. (Nearest Integer)
72. The osmotic pressure of a living cell is 12 atm at 300 K. The strength of sodium chloride solution that is isotonic with the living cell at this temperature is _____ g L^{-1} . (Nearest integer)
Given : $R = 0.08 \text{ L atm K}^{-1} \text{ mol}^{-1}$
Assume complete dissociation of NaCl
(Given : Molar mass of Na and Cl are 23 and 35.5 g mol^{-1} respectively.)
73. Identify the metal ions among Co^{2+} , Ni^{2+} , Fe^{2+} , V^{3+} and Ti^{2+} having a spin-only magnetic

moment value more than 3.0 BM. The sum of unpaired electrons present in the high spin octahedral complexes formed by those metal ions is _____.

74. A substance 'X' (1.5 g) dissolved in 150 g of a solvent 'Y' (molar mass = 300 g mol^{-1}) led to an elevation of the boiling point by 0.5 K. The relative lowering in the vapour pressure of the solvent 'Y' is _____ $\times 10^{-2}$. (nearest integer)

[Given : K_b of the solvent = 5.0 K kg mol^{-1}]

Assume the solution to be dilute and no association or dissociation of X takes place in solution.

75. MX is a sparingly soluble salt that follows the given solubility equilibrium at 298 K.

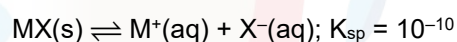

If the standard reduction potential for $M^+(aq) \xrightarrow{+e^-} M(s)$ is $(E_{M^+/M}^\ominus) = 0.79 \text{ V}$,

then the value of the standard reduction potential for the metal/metal insoluble salt electrode $E_{X^-/MX(s)/M}^\ominus$ is _____ mV. (nearest integer)

[Given : $\frac{2.303 RT}{F} = 0.059 \text{ V}$]





SANTOSH
Academia

IIT-JEE | NEET | Foundation

21-Jan-2026
(Evening)

Actual Paper JEE Main-2026_Phase-1

Answers

Mathematics

1. (3)
2. (3)
3. (2)
4. (1)
5. (3)
6. (1)
7. (1)
8. (2)
9. (4)
10. (2)
11. (4)
12. (4)
13. (2)
14. (3)
15. (1)
16. (4)
17. (1)
18. (1)
19. (2)
20. (2)
21. (2)
22. (9)
23. (32)
24. (65)
25. (2)

Physics

26. (2)
27. (4)
28. (2)
29. (3)
30. (3)
31. (4)
32. (1)
33. (2)
34. (3)
35. (2)
36. (1)
37. (4)
38. (1)
39. (3)
40. (1)
41. (1)
42. (1)
43. (4)
44. (2)
45. (1)
46. (5)
47. (350)
48. (14)
49. (10)
50. (1800)

Chemistry

51. (1)
52. (2)
53. (4)
54. (1)
55. (3)
56. (3)
57. (2)
58. (1)
59. (1)
60. (2)
61. (2)
62. (2)
63. (1)
64. (2)
65. (1)
66. (2)
67. (2)
68. (1)
69. (4)
70. (3)
71. (100)
72. (15)
73. (7)
74. (3)
75. (200)



SANTOSH
Academia
IIT-JEE | NEET | Foundation

Ghaziabad

+91 93114 41940

+91 93114 41879

Visit Us

www.santoshacademia.com

Solution

1. Answer (3)

There is exactly one intersection point of the line

$$\alpha x + 4y = \sqrt{7} \text{ and the ellipse } 3x^2 + 4y^2 = 1$$

$$\Rightarrow 3x^2 + 4\left(\frac{\sqrt{7} - \alpha x}{4}\right)^2 = 1$$

$$12x^2 + 7 + \alpha^2 x^2 - 2\sqrt{7}\alpha x - 4 = 0$$

$$(12 + \alpha^2)x^2 - 2\sqrt{7}\alpha x + 3 = 0$$

$$\Rightarrow D = 0$$

$$28\alpha^2 = 12(12 + \alpha^2) \Rightarrow \alpha = \pm 3$$

\therefore Line touches Ellipse in first quadrant

\Rightarrow Slope of line is negative.

$$\Rightarrow \alpha = 3$$

$$\Rightarrow x^2 - \frac{2}{\sqrt{7}}x + \frac{1}{7} = 0 \Rightarrow x = \frac{1}{\sqrt{7}}$$

$$\Rightarrow y = \frac{\sqrt{7} - \alpha x}{4} = \frac{\sqrt{7} - \frac{3}{\sqrt{7}}}{4} = \frac{1}{\sqrt{7}}$$

$$\text{Point } P = \left(\frac{1}{\sqrt{7}}, \frac{1}{\sqrt{7}}\right)$$

$$E: \frac{x^2}{\frac{1}{3}} + \frac{y^2}{\frac{1}{4}} = 1 \Rightarrow \frac{1}{4} = \frac{1}{3}(1 - e^2) \Rightarrow e = \frac{1}{2}$$

$$\text{Equation of directrices are } x = \pm \frac{2}{\sqrt{3}}$$

$$\Rightarrow SP = ePM = \frac{1}{2} \left(\frac{2}{\sqrt{3}} - \frac{1}{\sqrt{7}} \right) = \frac{1}{\sqrt{3}} - \frac{1}{2\sqrt{7}}$$

$$S'P = ePM' = \frac{1}{2} \left(\frac{2}{\sqrt{3}} + \frac{1}{\sqrt{7}} \right) = \frac{1}{\sqrt{3}} + \frac{1}{2\sqrt{7}}$$

\Rightarrow Option (3) is Correct.

2. Answer (3)

$$|x^2 - 10| \leq 6$$

$$\Rightarrow -6 \leq x^2 - 10 \leq 6$$

$$\Rightarrow 4 \leq x^2 \leq 16$$

$$\Rightarrow 2 \leq |x| \leq 4$$

$$\Rightarrow x \in [-4, -2] \cup [2, 4]$$

$$\therefore |x - 2| > 1$$

$$\Rightarrow x - 2 > 1 \text{ or } x - 2 < -1$$

$$\Rightarrow x \in (-\infty, 1) \cup (3, \infty)$$

$$\Rightarrow A - B = [2, 3]$$

$$\Rightarrow A \cup B = (-\infty, 1) \cup [2, \infty)$$

$$\Rightarrow B - A = (-\infty, -4) \cup (-2, 1) \cup (4, \infty)$$

$$\Rightarrow A \cap B = [-4, -2] \cup (3, 4]$$

\Rightarrow Option (3) is Correct.

3. Answer (2)

$$A(4t_1^2, 8t_1) \equiv (16, 16)$$

$$\Rightarrow t = 2$$

$$B(4t_2^2, 8t_2)$$

$\therefore AB$ is focal chord $\Rightarrow t_1 t_2 = -1$

$$\Rightarrow t_2 = -\frac{1}{2}$$

$$\Rightarrow B(1, -4)$$

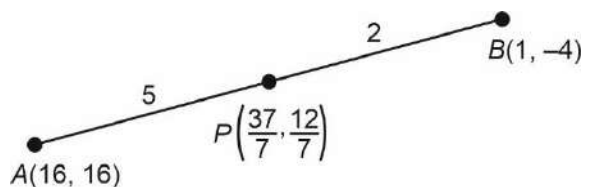

$$\Rightarrow \alpha + \beta = \frac{49}{7} = 7$$

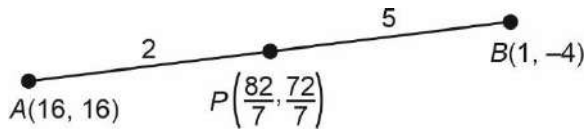

$$\Rightarrow \alpha + \beta = 22$$

\Rightarrow Option (2) is correct.

4. Answer (1)

$$\text{Exponent of 7 in } 101! = \left[\frac{101}{7} \right] + \left[\frac{101}{7^2} \right] + \dots$$

(where $[\cdot]$ is G.I.F.)

$$= 14 + 2 = 16$$

5. Answer (3)

$$R = \{(2, 2), (2, 3), (2, 5), (2, 7), (2, 9), \\ (3, 2), (3, 3), (3, 5), (3, 7), (3, 9), \\ (5, 5), (5, 7), (5, 9), \\ (7, 5), (7, 7), (7, 9), \\ (9, 7), (9, 9)\}$$

$$\Rightarrow l = 18$$

To make R symmetric, at least following elements should be added.

$$(5, 2), (7, 2), (9, 2), (5, 3), (7, 3), (9, 3), (9, 5)$$

$$\Rightarrow m = 7$$

$$\Rightarrow l + m = 25$$

Option (3) is correct.

6. Answer (1)

$$\sigma^2 + \mu^2 = 2 = 0^2 \times \left(\frac{2a+1}{30} \right)$$

$$+ 1^2 \left(\frac{8a-1}{30} \right) + 2^2 \left(\frac{4a+1}{30} \right) + 3b$$

After solving:

$$24a + 270b = 57 \quad \dots(i)$$

$$\sum xp(x) = 1$$

$$\Rightarrow \frac{2a+1}{30} + \frac{8a-1}{30} + \frac{4a+1}{30} + b = 1$$

$$\Rightarrow b = \frac{2a-14a}{30} \quad \dots(ii)$$

solving (i) and (ii)

$$a = 2, b = \frac{1}{30}$$

$$\frac{a}{b} = 60$$

7. Answer (1)

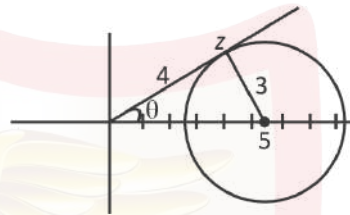

$$\Rightarrow \arg(z) = \sin^{-1} \left(\frac{3}{5} \right) = \tan^{-1} \left(\frac{3}{4} \right)$$

$$\Rightarrow z = |z|^{\theta}$$

$$= 4 \times (\cos\theta + i\sin\theta)$$

$$= 4 \times \left(\frac{4}{5} + i \frac{3}{5} \right)$$

$$= \frac{16}{5} + \frac{12i}{5} \quad \Rightarrow 5z = 16 + 12i$$

$$5zi = 16i - 12$$

$$\left(\frac{5z-12}{5zi+16} \right) = \frac{(4+12i)}{(4+16i)} = \frac{(1+3i)}{(1+4i)}$$

$$\Rightarrow \left| \frac{5z-12}{5zi+16} \right| = \frac{\sqrt{10}}{\sqrt{17}}$$

$$34 \left| \frac{5z-12}{5zi+16} \right|^2 = 34 \times \frac{10}{17} = 20.$$

8. Answer (2)

$$\text{Equation of line } L_1: \frac{x-2}{-3} = \frac{y-6}{2} = \frac{z-7}{4}$$

$$\text{Equation of line } L_2: \frac{x-4}{2} = \frac{y-3}{1} = \frac{z-5}{3}$$

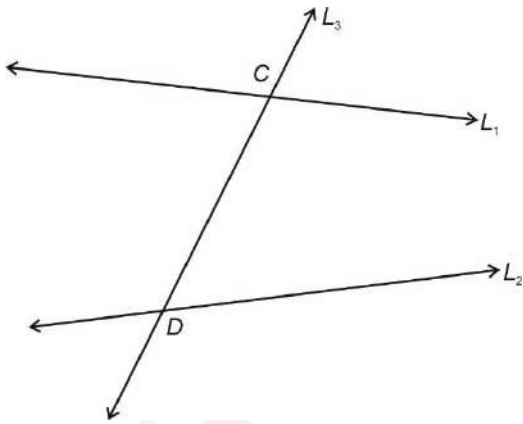

Let coordinate of $C = (-3\lambda + 2, 2\lambda + 6, 4\lambda + 7)$

and coordinate of $D = (2\mu + 4, \mu + 3, 3\mu + 5)$

$$\frac{2\mu + 3\lambda + 2}{-3} = \frac{\mu - 2\lambda - 3}{5} = \frac{3\mu - 4\lambda - 2}{16}$$

Solving (1) : $13\mu + 9\lambda = -1$

Solving (2) : $41\mu - 36\lambda = -26$

Solving above equations

$$\mu = 2, \lambda = -3$$

$$\overline{CD} = -3\hat{i} + 5\hat{j} + 16\hat{k}$$

$$|\overline{CD}|^2 = 9 + 25 + 256 = 290$$

9. Answer (4)

$$3x + y + 4z = 3$$

$$2x + \alpha y - z = -3$$

$$x + 2y + z = 0$$

$$\Delta = \begin{vmatrix} 3 & 1 & 4 \\ 2 & \alpha & -1 \\ 1 & 2 & 1 \end{vmatrix} = 0$$

$$\Rightarrow 3(\alpha + 2) - 1(2 + 1) + 4(4 - \alpha) = 0$$

$$\Rightarrow \alpha = 19$$

$$\Delta_1 = \begin{vmatrix} 3 & 1 & 4 \\ -1 & 19 & -1 \\ 0 & 2 & 1 \end{vmatrix}$$

$$= 3(19 + 2) - 1(-3) + 9(-6)$$

$$= 63 + 3 - 24$$

$$= 42 \neq 0$$

10. Answer (2)

$$A = \begin{bmatrix} 3 & -4 \\ 1 & -1 \end{bmatrix}$$

$$A^2 = \begin{bmatrix} 5 & -8 \\ 2 & -3 \end{bmatrix}$$

$$A^3 = \begin{bmatrix} 7 & -12 \\ 3 & -5 \end{bmatrix}$$

$$A^n = \begin{bmatrix} 2n+1 & -4n \\ n & -(2n-1) \end{bmatrix}$$

$$\Rightarrow A^{15} = \begin{bmatrix} 31 & -60 \\ 15 & -29 \end{bmatrix}$$

$$A^{15} + B = \begin{bmatrix} 2 & -11 \\ 2 & -11 \end{bmatrix}$$

$$(A^{15} + B) \begin{bmatrix} x \\ y \end{bmatrix} = \begin{bmatrix} 0 \\ 0 \end{bmatrix}$$

$$\begin{bmatrix} 2 & -11 \\ 2 & -11 \end{bmatrix} \begin{bmatrix} x \\ y \end{bmatrix} = \begin{bmatrix} 0 \\ 0 \end{bmatrix}$$

$$2x - 11y = 0$$

$$\therefore x = 11, y = 2$$

11. Answer (4)

$$\text{Let } f(1) = a$$

$$f'(2) = b$$

$$f'(3) = c$$

$$f(x) = x^3 + ax^2 + bx + c$$

$$f'(x) = 3x^2 + 2ax + b$$

$$f'(1) = a = 3 + 2a + b \Rightarrow a + b = 3 \dots (1)$$

$$f''(x) = 6x + 2a$$

$$\Rightarrow f''(2) = 12 + 2a = \frac{b}{2} \Rightarrow 4a - b = -24$$

$$\Rightarrow f''(x) = 6$$

$$\Rightarrow f''(3) = c = 6$$

$$\Rightarrow a = \frac{-27}{5}, b = \frac{12}{5}$$

$$f'(5) = 75 + 10a + b$$

$$= 75 - 54 + \frac{12}{5}$$

$$= 21 + \frac{12}{5} = \frac{117}{5}$$

12. Answer (4)

$$g(x) = f(\tan^2 x - 2 \tan x + a)$$

$$g'(x) = f'(\tan^2 x - 2 \tan x + a)(2 \tan x - 2) \sec^2 x$$

$$= f'((\tan x - 1)^2 + a - 1)(2 \tan x - 2) \sec^2 x$$

$f(x)$ is increasing

$$f(a - 1) = 0$$

$$f(x) < 0 \text{ for } x < a - 1$$

$$f(x) > 0 \text{ for } x > a - 1$$

$$(\tan x - 1)^2 + (a - 1) > a - 1$$

$$\Rightarrow f'((\tan x - 1)^2 + (a - 1)) > f'(a - 1)$$

$$\Rightarrow f'((\tan x - 1)^2 + (a - 1)) > 0$$

\therefore For $x \in \left(0, \frac{\pi}{4}\right)$, $g'(x) < 0 \Rightarrow g(x)$ is

decreasing

For $x \in \left(\frac{\pi}{4}, \frac{\pi}{2}\right)$, $g'(x) > 0 \Rightarrow g(x)$ is increasing

13. Answer (2)

$$(\sec x) \frac{dy}{dx} - 2y = 2 + 3 \sin x$$

$$\Rightarrow \frac{dy}{dx} - 2 \cos x y = 2 \cos x + 3 \sin x \cdot \cos x$$

$$\text{IF} = e^{-2 \sin x}$$

$$y \cdot e^{-2 \sin x} = \int e^{-2 \sin x} \cdot \cos x (2 + 3 \sin x) dx$$

$$\sin x = t \Rightarrow \cos x dx = dt$$

$$y \cdot e^{-2 \sin x} = \int e^{-2t} (2 + 3t) dt$$

$$= 2 \frac{e^{-2t}}{-2} + 3 \int t \cdot e^{-2t} dt$$

$$= -e^{-2t} + 3 \left(\frac{t \cdot e^{-2t}}{-2} + \frac{1}{2} \int e^{-2t} dt \right)$$

$$-e^{-2t} + 3 \left(-\frac{te^{-2t}}{2} - \frac{1}{4} e^{-2t} \right) + c$$

$$y = -1 - \frac{3}{2} (\sin x) - \frac{3}{4} + ce^{2 \sin x}$$

$$= -\frac{7}{4} - \frac{3}{2} \sin x + c \cdot e^{2 \sin x}$$

$$y(0) = -\frac{7}{4} \Rightarrow c = 0$$

$$y = -\frac{7}{4} - \frac{3}{2} \sin x$$

$$y(\pi/6) = -\frac{7}{4} - \frac{3}{4} = -\frac{10}{4} = -\frac{5}{2}$$

14. Answer (3)

$$\frac{a_2}{2} = a_1 r \Rightarrow a_2 = 2a_1 r = \sqrt{2} a_1$$

$$\frac{a_3}{2^2} = a_1 r^2 \Rightarrow a_3 = 4a_1 r^2 = 2a_1$$

$$\frac{a_4}{2^3} = a_1 r^3 \Rightarrow a_4 = 8a_1 r^3 = 2\sqrt{2} a_1$$

$$a_1 + a_2 + \dots + a_{10} = 62$$

$$= a_1 + \sqrt{2} a_1 + 2a_1 + \dots = 62$$

$$= \frac{a_1 ((\sqrt{2})^{10} - 1)}{\sqrt{2} - 1} = 62$$

$$= a_1 = 2(\sqrt{2} - 1)$$

15. Answer (1)

$$x(x+2) + (x+2)(x+4) + \dots + (x+2n-2)(x+$$

$$2n) = \frac{8n}{3}$$

$$T_r = (x+2r-2)(x+2r), r = 1, 2, \dots, n$$

$$\sum T_r = \sum x^2 + 2x \sum (2r-1) + \sum (r^2 - r)$$

=

$$nx^2 + 2x(n^2) + 4 \left(\frac{(n)(n+1)(2n+1)}{6} - \frac{n(n+1)}{2} \right)$$

$$\Rightarrow nx^2 + 2xn^2 + \frac{4n(n^2-1)}{3} = \frac{8n}{3}$$

$$\Rightarrow x^2 + 2nx + \frac{4(n^2-1)}{3} - \frac{8}{3} = 0$$

$$\Rightarrow 3x^2 + 6nx + 4n^2 - 12 = 0$$

$$|\alpha - \beta| = 2$$

$$\Rightarrow (\alpha + \beta)^2 - 4\alpha\beta = 4$$

$$\Rightarrow 4n^2 - 4\left(\frac{4n^2-12}{3}\right) = 4$$

$$\Rightarrow 12n^2 - 16n^2 + 48 - 12 = 0$$

$$\Rightarrow 4n^2 = 36$$

$$\Rightarrow n^2 = 9$$

$$\Rightarrow n = 3$$

16. Answer (4)

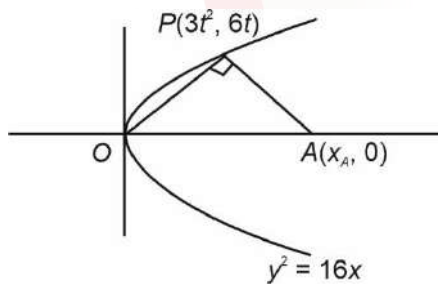

$$M_{OP} \cdot M_{PA} = -1.$$

$$\frac{2}{t} \cdot \frac{6t}{3t^2 - x_A} = -1$$

$$12 = x_A - 3t^2$$

$$x_A = 3t^2 - 12$$

$$h = \frac{x_A + 3t^2}{3}, k = \frac{6t}{3}$$

$$3h = 3t + 3t^2 - 12 \quad k = 2t$$

$$h = 2t^2 - 4$$

$$h = 2\left(\frac{k}{2}\right)^2 - 4$$

$$2h = k^2 - 8$$

$$h \rightarrow x \quad k \rightarrow y$$

$$2x = y^2 - 8$$

$$y^2 - 2x - 8 = 0$$

17. Answer (1)

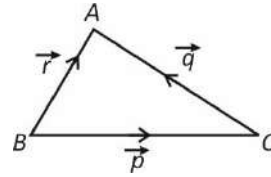

$$\therefore \vec{p} + \vec{q} = \vec{r} \dots(1)$$

Squaring both sides we get

$$|\vec{p}|^2 + |\vec{q}|^2 + 2\vec{p} \cdot \vec{q} = |\vec{r}|^2$$

$$12 + 4 + 8\sqrt{3} \cdot \frac{1}{\sqrt{3}} = |\vec{r}|^2$$

$$\therefore |\vec{r}| = \sqrt{24}.$$

from equation (1) : $\vec{p} \times (\vec{p} + \vec{q}) = \vec{p} \times \vec{r}$.

$$\vec{p} \times \vec{q} = \vec{p} \times \vec{r}.$$

$$\therefore \vec{p} \times (\vec{q} - 3\vec{r}) = \vec{p} \times \vec{q} - 3\vec{p} \times \vec{r}$$

$$= -2\vec{p} \times \vec{q}$$

$$\therefore |\vec{p} \times (\vec{q} - 3\vec{r})|^2 + 3|\vec{r}|^2$$

$$= 4 \cdot |\vec{p} \times \vec{q}|^2 + 3 \times 24.$$

$$= 4(|\vec{p}|^2 - |\vec{q}|^2 - (\vec{p} \cdot \vec{q})^2) + 3 \times 24$$

$$= 4(12 \cdot 4 - 16) + 72 = 200$$

18. Answer (1)

$$x^2 = 2ax + (3a + 10) = 0$$

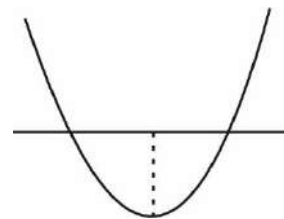

$$\Rightarrow f(1) < 0$$

$$\Rightarrow 1 + 2a + 3a + 10 < 0$$

$$5a + 11 < 0$$

$$a < \frac{-11}{5}$$

19. Answer (2)

$$1 - 2x \leq y \leq 4 - x^2$$

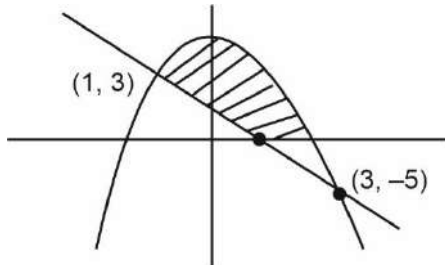

$$\text{Area} = \int_0^2 (4 - x^2) dx - \frac{1}{2} \times \frac{1}{2} \times 1$$

$$4x - \frac{x^3}{3} \Big|_0^2 - \frac{1}{4}$$

$$8 - \frac{8}{3} - \frac{1}{4}$$

$$\frac{61}{12} = \frac{\alpha}{\beta} \therefore \alpha + \beta = 73$$

20. Answer (2)

$$A = (-3, 5, 2), P(-2, r, 1)$$

$$L: \vec{r} = \langle -3, 5, 2 \rangle + t \langle 1, 1, 1 \rangle$$

$$\text{dih} = \frac{|\vec{AP} \times \vec{d}|}{|\vec{d}|}$$

$$\vec{AP} = \langle 1, r-5, -1 \rangle \quad \vec{d} = \langle 1, 1, 1 \rangle$$

$$|\vec{AP} \times \vec{d}|^2 = \begin{vmatrix} \hat{i} & \hat{j} & \hat{k} \\ 1 & r-5 & -1 \\ 1 & 1 & 1 \end{vmatrix} = \langle r-4, -2, 6-r \rangle$$

$$\Rightarrow \sqrt{\frac{14}{3}} = \frac{\sqrt{(r-4)^2 + 4 + (6-r)^2}}{\sqrt{3}}$$

SOBS

$$14 = r^2 + 16 - 8r + 4 + 36 + r^2 - 12r$$

$$2r^2 - 20r + 56 = 14$$

$$2r^2 - 20r + 42 = 0$$

$$r^2 - 10r + 21 = 0$$

$$r = 3 \text{ or } 7$$

$$\text{Sum} = 7 + 3 = 10$$

21. Answer (2)

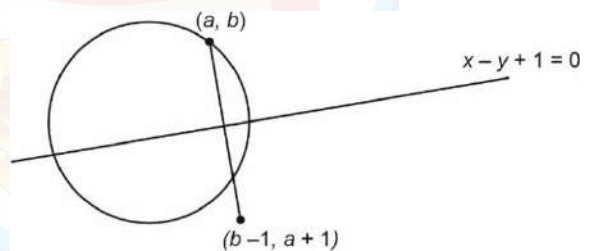

$$\Rightarrow \frac{x-a}{1} = \frac{y-b}{-1} = -2 \frac{(a-b+1)}{2}$$

$$= -a + b - 1$$

$$\Rightarrow x = b-1, y = a+1$$

$$\Rightarrow ((b-1), (a+1)) \text{ lie on } 5x + y + 2 = 0$$

$$\Rightarrow 5(b-1) + (a+1) + 2 = 0$$

$$a + 5b - 2 = 0$$

$$\text{and also } a^2 + b^2 = 4$$

$$\Rightarrow a^2 + \left(\frac{2-a}{5}\right)^2 = 4$$

$$\Rightarrow 25a^2 + (a^2 - 4a + 4) = 100$$

$$\Rightarrow 26a^2 - 4a - 96 = 0$$

$$\text{Sum of all } a = \frac{2}{13}$$

$$\Rightarrow \frac{13 \times 2}{13} = 2$$

22. Answer (9)

$$I = 4 \int_0^1 \cot^{-1}(1 - 2x + 4x^2) dx$$

$$\text{Since } 1 - 2x + 4x^2 = \left(2x - \frac{1}{2}\right)^2 + \frac{3}{4} > 0$$

$$\Rightarrow I = 4 \int_0^1 \tan^{-1} \left(\frac{1}{1+2x(2x-1)} \right) dx$$

$$I = 4 \int_0^1 (\tan^{-1}(2x) - \tan^{-1}(2x-1)) dx$$

$$= 4 \int_0^1 \tan^{-1}(2x) dx - 4 \int_0^1 \tan^{-1}(2x-1) dx$$

$$\text{for } \int_0^1 \tan^{-1}(2x-1) dx = \int_{-1}^1 \frac{\tan^{-1}(t)}{2} dt = 0$$

$$\Rightarrow I = 4 \int_0^1 \tan^{-1}(2x) dx$$

$$= 4(x \tan^{-1} 2x) \Big|_0^1 - 4 \int_0^1 \frac{x}{1+4x^2} \times 2 dx$$

$$= 4 \tan^{-1} 2 - 4 \frac{\ln(1+4x^2)}{4} \Big|_0^1$$

$$= 4 \tan^{-1} 2 - \ln 5 \Rightarrow a = 4, b = 1$$

$$\Rightarrow 2(4) + 1 = 9$$

23. Answer (32)

Notice that

$$\frac{1}{{}^n C_r} + \frac{1}{{}^n C_{r+1}} = \frac{{}^n C_{r+1} + {}^n C_r}{{}^n C_r \cdot {}^n C_{r+1}} = \frac{{}^{n+1} C_{r+1}}{{}^n C_r \cdot {}^n C_{r+1}}$$

$$= \frac{\frac{n+1}{r+1} + {}^n C_r}{{}^n C_r \cdot {}^n C_{r+1}} = \frac{(n+1)}{(r+1) \cdot \frac{n}{r+1} \cdot {}^{n-1} C_r} = \frac{n+1}{n \cdot {}^{n-1} C_r}$$

$$\therefore \left(\frac{1}{{}^{15} C_0} + \frac{1}{{}^{15} C_1} \right) \left(\frac{1}{{}^{15} C_1} + \frac{1}{{}^{15} C_2} \right) \dots \left(\frac{1}{{}^{15} C_{12}} + \frac{1}{{}^{15} C_{13}} \right)$$

$$= \frac{16}{15 \cdot {}^{14} C_0} \cdot \frac{16}{15 \cdot {}^{14} C_1} \dots \frac{16}{15 \cdot {}^{14} C_{12}}$$

$$= \frac{\left(\frac{16}{15}\right)^{13}}{{}^{14} C_0 \cdot {}^{14} C_1 \cdot {}^{14} C_2 \dots {}^{14} C_{12}}$$

$$\therefore \alpha = \frac{16}{15}$$

$$\therefore 30\alpha = 32.$$

24. Answer (65)

$$(\sin^{-1} x)^2 + (\cos^{-1} x)^2$$

$$= (\sin^{-1} x + \cos^{-1} x)^2 - 2 \sin^{-1} x \left(\frac{\pi}{2} - \sin^{-1} x \right)$$

$$= \frac{\pi^2}{4} + 2(\sin^{-1} x)^2 - \pi \sin^{-1} x$$

$$\frac{\pi^2}{4} + 2 \left((\sin^{-1} x) - \frac{\pi}{4} \right)^2 - 2 \times \frac{\pi^2}{16}$$

$$= \frac{\pi^2}{8} + 2(\sin^{-1} x - \frac{\pi}{4})^2$$

For maximum,

Since,

$$\sin^{-1} x \in \left[-\frac{\pi}{3}, \frac{\pi}{4} \right] \text{ at}$$

$$\sin^{-1} x = -\frac{\pi}{3}$$

$$\Rightarrow \text{maximum value} = \frac{29}{36} \pi^2$$

$$\Rightarrow \frac{m}{n} = \frac{29}{36} \Rightarrow m + n = 65$$

25. Answer (2)

$$(\sin^{-1} x)^2 + (\cos^{-1} x)^2$$

$$= (\sin^{-1} x + \cos^{-1} x)^2 - 2 \sin^{-1} x \left(\frac{\pi}{2} - \sin^{-1} x \right)$$

$$= \frac{\pi^2}{4} + 2(\sin^{-1} x)^2 - \pi \sin^{-1} x$$

$$\frac{\pi^2}{4} + 2 \left((\sin^{-1} x) - \frac{\pi}{4} \right)^2 - 2 \times \frac{\pi^2}{16}$$



$$= \frac{\pi^2}{8} + 2(\sin^{-1}x \mid \frac{\pi}{4})^2$$

For maximum,

Since,

$$\sin^{-1}x \in \left[-\frac{\pi}{3}, \frac{\pi}{4}\right] \text{ at}$$

$$\sin^{-1}x = -\frac{\pi}{3}$$

$$\Rightarrow \text{maximum value} = \frac{29}{36}\pi^2$$

$$\Rightarrow \frac{m}{n} = \frac{29}{36} \Rightarrow m + n = 65$$

26. Answer (2)

$$\frac{\mu_0 I \hat{j}}{2\pi r} - \frac{\mu_0 I \hat{j}}{2r}$$

$$\Rightarrow \vec{B} = \frac{-\mu_0 I}{2\pi r}(\pi - 1)\hat{i}$$

27. Answer (4)

$$\tau = (M - m)gR$$

$$\alpha = \frac{(M - m)gR}{\left[MR^2 + mR^2 + MR^2 + \frac{2M4R^2}{12}\right]}$$

$$\Rightarrow \alpha = \frac{(M - m)gR}{\left(\frac{8M}{3} + m\right)R}$$

$$\Rightarrow a = \alpha R = \frac{(M - m)g}{\left(\frac{8}{3}M + m\right)}$$

28. Answer (2)

$$E = \frac{-E_0}{n^2} = \frac{-E_0}{25}$$

$$\Rightarrow n = 5$$

$$\text{So } \frac{h5}{2\pi} = L$$

$$\Rightarrow \frac{2\pi L}{h} = 5$$

29. Answer (3)

$$\frac{KQ^2}{4R} - \frac{Gm^2}{4R} + \frac{1}{2}mu^2 \times 2 = \frac{KQ^2}{2R} - \frac{Gm^2}{2R}$$

$$\Rightarrow mu^2 = \frac{KQ^2}{4R} - \frac{Gm^2}{4R}$$

$$\Rightarrow u = \sqrt{\frac{KQ^2}{4mR} \left(1 - \frac{Gm^2}{KQ^2}\right)}$$

30. Answer (3)

$$N = m\omega^2 R$$

$$mg \leq \mu m\omega^2 R$$

$$\text{so } \omega \geq \sqrt{\frac{g}{\mu R}}$$

31. Answer (4)

We know that energy term oscillates with twice the frequency of SHM.

$$\text{so } \omega_0 = \frac{176}{2}$$

$$\Rightarrow f = \frac{88 \times 7}{2 \times 22}$$

$$\Rightarrow f = 14$$

32. Answer (1)

$$\Delta t = \frac{400}{10} = 40 \text{ sec}$$

$$\text{and } \Delta x = 5 \times 40 = 200 \text{ m}$$

33. Answer (2)

$$q = q_0 \cos(\omega t)$$

$$q_1^2 = \frac{75}{100} q_0^2 \Rightarrow q_1 = \frac{\sqrt{3}}{2} q_0$$

$$\text{So, } \omega t = \frac{\pi}{6} \Rightarrow t = \frac{\pi\sqrt{LC}}{6}$$

34. Answer (3)

$$I = \frac{2.5}{5} = \frac{1}{2} \text{ A}$$

$$\Delta V = 4 \times \frac{1}{2} \text{ volts}$$

$$q = C\Delta V = 10 \mu\text{F}$$

35. Answer (2)

After decimal least number of digits to be considered.

36. Answer (1)

$$I = \frac{E}{R+r}$$

$$P = \frac{E^2}{(R+r)} \cdot R$$

$$\text{For } P_{\max} \Rightarrow R = r$$

37. Answer (4)

$$h = \frac{2T \cos \theta}{\rho g r}$$

$$\text{So, } \frac{h_1}{h_2} = \frac{T_1 r_2}{T_2 r_1}$$

$$\Rightarrow \frac{r_1}{r_2} = \frac{T_1 h_2}{T_2 h_1}$$

Since $r_1 > r_2$

So, for $T_1 = T_2$

$$h_1 < h_2$$

38. Answer (1)

$$V_{\text{r.m.s.}} = \sqrt{\frac{3KT}{m}}$$

$$\Rightarrow V_{\text{O}_2} = \sqrt{\frac{3K \times 320}{32 m_{\text{O}}}}$$

$$\text{And } V_{\text{N}_2} = \sqrt{\frac{3KT}{2m_{\text{O}}}}$$

$$\Rightarrow T = 20 \text{ K}$$

$$= -253 \text{ }^\circ\text{C}$$

39. Answer (3)

$$V_A = 20 \text{ m/s; } V_B = 10 \text{ m/s}$$

$$\text{So } L_{A/B} = 10^3 \times 10 \times 10 = 10^5 \text{ J.s.}$$

40. Answer (1)

$$\frac{1}{R} + \frac{1}{2R+x} = \frac{1}{x}$$

$$\Rightarrow x^2 + 2Rx - 2R^2 = 0$$

$$\Rightarrow x = R(\sqrt{3} - 1)$$

41. Answer (1)

$$\omega = \frac{\lambda D}{d}$$

$$\text{Angular fringe width} = \frac{\lambda}{d}$$

42. Answer (1)

\therefore galvanometer shows zero

$$\text{So, } 6 \times R_{PB} = 4R_{AP}$$

$$\frac{I_{AP}}{50 - I_{AP}} = \frac{3}{2}$$

$$I_{AP} = 30 \text{ cm}$$

43. Answer (4)

$$x = \alpha t^2 + \beta t + \gamma$$

$$v = 2\alpha t + \beta$$

$$v(3) = 6\alpha + \beta = 7 \text{ m/s}$$

$$v(2) = 4\alpha + \beta = 5 \text{ m/s}$$

$$\omega = \Delta kt$$

$$= \frac{1}{2} \cdot 2 \cdot (7^2 - 5^2)$$

$$= 24$$



44. Answer (2)

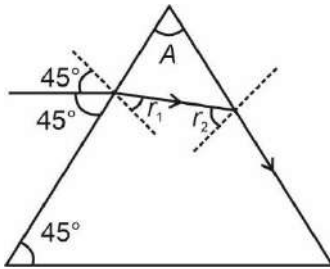

$$\sin 45^\circ = \sqrt{2} \sin r_1$$

$$r_1 = 30^\circ$$

$$\sqrt{2} \sin r_2 = 1$$

$$r_2 = 45^\circ$$

$$A = r_1 + r_2$$

$$= 75^\circ$$

$$\theta = 180^\circ - 45^\circ - 75^\circ$$

$$= 60^\circ$$

45. Answer (1)

$$V_0 = \frac{2r^2g}{9\eta}(\sigma - \rho)$$

$$\frac{V_0\eta}{r^2} = \text{constant}$$

$$\frac{\Delta\eta}{\eta} = \frac{2\Delta r}{r} + \frac{\Delta V_0}{V_0}$$

46. Answer (5)

$$V_T \propto r^2$$

$$V_T = \left(\frac{3}{6}\right)^2 \cdot 20$$

$$= 5 \text{ cm/s}$$

47. Answer (350)

$$Q = \Delta V + W$$

$$nC_p\Delta T = nC_v\Delta T + nR\Delta T$$

$$Q = \frac{7}{2}W = 350$$

48. Answer (14)

$$d = 0.4 \text{ mm} \quad D = 1 \text{ m}$$

$$(\mu - 1)t = \frac{yd}{D}$$

$$\mu = 1 + \frac{yd}{tD}$$

$$= 1.4 = \frac{14}{10}$$

49. Answer (10)

$$T = \frac{h}{\sqrt{2mkE}}$$

$$= \frac{6.6 \times 10^{-34}}{\sqrt{2 \times 6 \times 10^{-27} \times 3 \times 10^{-19} \times 1.21}}$$

$$= \frac{6.6}{6.6} \times 10^{-11}$$

$$= 10 \times 10^{-12}$$

50. Answer (1800)

$$\frac{J_c}{J_d} = \frac{\sigma}{\omega \epsilon_0}$$

$$= \frac{2\sigma}{f \cdot 4\pi \epsilon_0}$$

$$= \frac{2 \times 10 \times 9 \times 10^9}{10^8}$$

$$= 1800$$

51. Answer (1)

(A) In Mn_2O_7 Mn is in +7 highest oxidation state.

(B) Correct

(C) Mn_2O_7 is covalent

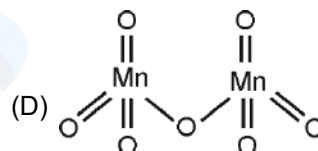

52. Answer (2)

$$[\text{Cr}(\text{H}_2\text{O})_6]^{2+} \Rightarrow t_{2g}^3 e_g^1$$

$$\text{CFSE} = (-0.4 \times 3 + 0.6 \times 1) \Delta_0$$

$$= (-1.2 + 0.6) \Delta_0$$

$$= -0.6 \Delta_0$$

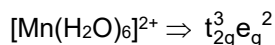

$$\text{CFSE} = (-0.4 \times 3 + 0.6 \times 2) \Delta_0$$

$$= 0$$

S – I is correct

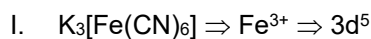

$$\text{Unpaired } e^- (n) = 1$$

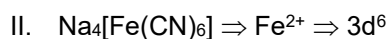

$$n = 0$$

$$\mu_I > \mu_{II}$$

S – II is correct

53. Answer (4)

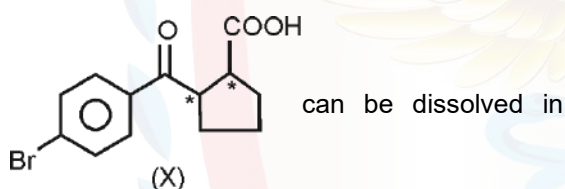

NaHCO_3 solution due to presence of $-\text{COOH}$ group.

It has 2-chiral centre

S – I is correct



Number of sp^3 carbon = 2

Number of sp^2 carbon = 1

Number of sp carbon = 1

54. Answer (1)

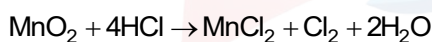

$$n_{\text{MnO}_2} = \frac{8.7}{87} = 0.1 \text{ mol}$$

mole of MnO_2 = mol of Cl_2

$$\text{Mass of } \text{Cl}_2 = 0.1 \times 71 \text{ g}$$

$$= 7.1 \text{ g}$$

55. Answer (3)

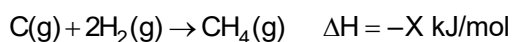

$$Y + 2 \times Z - 4\text{BE}_{\text{C-H}} = -X$$

$$X + Y + 2Z = 4\text{BE}_{\text{C-H}}$$

$$\text{BE}_{\text{CH}} = \frac{X + Y + 2Z}{4}$$

56. Answer (3)

Standard potential of cell remains constant with time.

57. Answer (2)

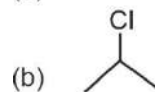

(c) can show optical isomerism

$$\% \text{C} = \frac{12 \times 4}{92.5} \times 100 = 51.89 \approx 52\%$$

58. Answer (1)

$$\text{BDE of } \text{F}_2 = 158.8 \text{ kJ/mol}$$

$$\text{Cl}_2 = 242.6 \text{ kJ/mol}$$

$$\text{Br}_2 = 192.8 \text{ kJ/mol}$$

$$\text{I}_2 = 151.1 \text{ kJ/mol}$$

$$\text{Order} = \text{Cl}_2 > \text{Br}_2 > \text{F}_2 > \text{I}_2$$

Statement I is correct

More the charge density on cation more will be covalent character

$$\text{SnCl}_4(\text{Sn}^{4+}) > \text{SnCl}_2(\text{Sn}^{2+})$$

$$\text{PbCl}_4(\text{Pb}^{4+}) > \text{PbCl}_2(\text{Pb}^{2+})$$

$$\text{UF}_4(\text{U}^{4+}) < \text{UF}_6(\text{U}^{6+})$$

Statement II is false.

59. Answer (1)

As only KCN is given so it will follow $\text{S}_{\text{N}}2$ mechanism. Electron donor group via resonance will stabilise transition state.

The rate of $\text{S}_{\text{N}}2$ is:



$$b > a > d > c$$

60. Answer (2)

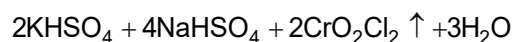

CrO_2Cl_2 gas is evolved in which Cr is in +6 oxidation state.

61. Answer (2)

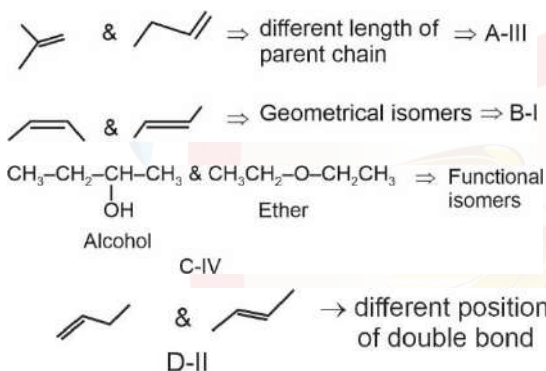

62. Answer (2)

Bond length **Values (pm)**

C – H 107

C – O 143

C = O 121

C \equiv N 116

Order A < D < C < B

63. Answer (1)

1st line of Paschen series

$$E \propto \left(\frac{1}{3^2} - \frac{1}{4^2} \right) \propto \frac{7}{144}$$

Second line of Balmer series

$$E \propto \left[\frac{1}{2^2} - \frac{1}{4^2} \right] = \frac{12}{64} = \frac{3}{16}$$

Third line of Paschen series

$$E \propto \left[\frac{1}{3^2} - \frac{1}{6^2} \right] \propto \frac{3}{36} \propto \frac{1}{12}$$

Fourth line of Bracket series

$$E \propto \left[\frac{1}{4^2} - \frac{1}{8^2} \right] \propto \frac{3}{64}$$

Order of energy

B > C > A > D

64. Answer (2)

For Al, Mg, Mg^{2+} , Al^{3+}

Al < Mg

$Al^{3+} < Mg^{2+}$

Statement I false

Correct order of electron gain enthalpy

	Cl	Br	S	O
In kJ/mol	(-349)	-325	-200	-141

Statement II is true.

65. Answer (1)

$$\% \text{ of mass of phosphorus} \Rightarrow \frac{1.79 \times 62}{222 \times 1} \times 100 =$$

50%

66. Answer (2)

H_2 -Pd $BaSO_4 \Rightarrow$ Rosenmund reduction

$SnCl_2/HCl_2 \Rightarrow$ Stephen's reduction

$CrO_2Cl_2/CS_2 \Rightarrow$ Etard reaction

CO/HCl, Anhy $AlCl_3 \Rightarrow$ Gatterman Koch

A – II, B – IV, C – I, D – III

67. Answer (2)

Nucleophilic strength inversely depends on stability of -ve charge

$OH^- > PhO^- > CH_3COO^- > ClO_4^-$

68. Answer (1)

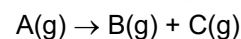

t = 0 1

t = 100 min 1 – P P P

1 + P = 1.5

(P = 0.5)

$$k = \frac{2.303}{100} \log \frac{1}{0.5} = \frac{2.303}{100} \times 0.3 = 6.9 \times 10^{-3}$$

69. Answer (4)

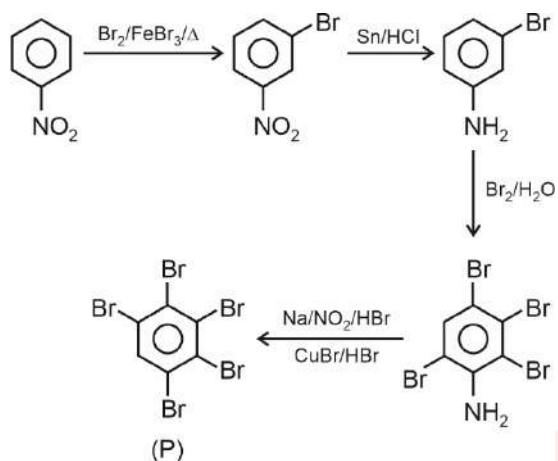

70. Answer (3)

 $(E_a)_{\text{acid catalysed}} \approx 6 \text{ kJ/mol}$ $(E_a)_{\text{enzyme catalysed}} \approx 2.15 \text{ kJ/mol}$

A correct

Nucleotides are joined together by phosphodiester linkage.

71. Answer (100)

Value of $K_{a1} \gg K_{a2}$

$$\therefore [A^{2-}] = K_{a2} = 10^{-13}$$

$$= 100 \times 10^{-15}$$

72. Answer (15)

$$\pi_{\text{NaCl}} = iCRT$$

$$12 = 2 \times \frac{n}{V} \times 0.08 \times 300$$

$$12 = 2 \times \frac{w}{58.5 \times V} \times 0.08 \times 300$$

$$14.625 = \frac{w}{V}$$

73. Answer (7)

$$\mu > 3.0 \text{ BM}$$

$$\sqrt{n(n+2)} > 3$$

$$n \geq 3$$

For $\text{Co}^{2+}(d^7)$ $n = 3$ For $\text{Ni}^{2+}(d^8)$ $n = 2$ For $\text{Fe}^{2+}(d^6)$ $n = 4$ For $\text{V}^{3+}(d^2)$ $n = 2$ For $\text{Ti}^{2+}(d^2)$ $n = 2$ Sum of unpaired e^- in high spin octahedral complex = 7

74. Answer (3)

$$\Delta T_b = K_b m$$

$$0.5 = 5 \times \frac{1.5 \times 1000}{M_0 \times 150}$$

$$M_0 = 100 \text{ g}$$

$$RLVP = X_{\text{solute}}$$

$$\approx \frac{1.5}{100 \times 150} \times 300$$

$$\approx 3 \times 10^{-2}$$

75. Answer (200)

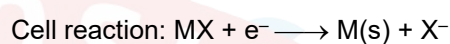

$$E_{X^-/MX/M}^{\circ} = E_{M^+/M}^{\circ} + \frac{0.059}{n} \log K_{sp}$$

$$E_{X^-/MX/M}^{\circ} = 0.79 + \frac{0.059}{1} \log 10^{-10}$$

$$E^{\circ} = 0.79 - 0.59$$

$$= 0.2 \text{ V}$$

$$= 200 \text{ mV}$$

